

Standardtype

Ventil in Ruhestellung geschlossen - (NC). Der erregte Magnet öffnet eine Vorsteuerbohrung und hebt direkt oder unterstützt von der Druckdifferenz den Kolben vom Hauptsitz. Das Ventil schließt durch Federkraft.

Standard type

Valve normally closed - NC. When energised, the solenoid will open/free the pilot chamber and the valve will open directly or servo assisted by pressure of the flow medium. The valve closes by spring power.



Steuerungsart: Type of control:	Zwangsgesteuert Force pilot operated	Metall. Innenteile: Metallic internals:	Messing und Edelstahl 1.4104 Brass and stainless steel (AISI 430F)
Konstruktion: Construction:	Kolbensitzventil Piston design	Dichtung: Sealing:	NBR NBR
Anschluss: Connection:	Flansch DN15-DN300 Flanges DN15-DN300	Einbaulage: Installation:	nur mit stehendem Magneten actuator only in upright position
Druck: Pressure:	0-40 bar (s. Tabelle) 0-40 bar (see table)	Anschlussspannung: Supply voltage:	AC: 24,42,110,230V 50/60Hz DC: 24,110,205V=
Durchflussmedium: Medium:	neutrale, gasförmige u. flüssige Medien neutral, gaseous and liquid fluids	Spannungstoleranz: Voltage tolerance:	+5% / -10% +5% / -10%
Viskosität: Viscosity:	22mm ² /s 22mm ² /s	Leistungsaufnahme: Power-consumption:	1322/3322 = 30 Watt 4242/5242 = 46 Watt 4272/5272 = 100 Watt 4352/5352 = 150 Watt 4402/5402 = 250 Watt
Mediumtemperatur: Medium temperature:	-10 bis +80°C -10 up to +80°C		
Umgebungstemperatur: Ambient temperature:	+35°C +35°C		
Ventilgehäuse: Body material:	../04../ = GG-25 / Cast iron ../05../ = GS-C25 / Cast steel ../08../ = Edelstahl - 1.4581/ Stainless steel (AISI 316Ti) ab DN65 Edelstahl 1.4408/ up to DN65 Stainless steel (AISI 316L)	Schutzart: Protection class:	IP65 nach DIN 40050 IP65 according to DIN 40050
		Einschaltdauer: Duty factor:	100% ED - VDE 0580 100% ED - VDE 0580
		Kabelanschluss: Cable connection:	Gerätestecker DIN 43650 oder Klemmkasten DIN 43650 - plug or terminal box

Die Kv-Werte in der Tabelle gelten jeweils für das größte angegebene Magnetsystem!*
In each case, the flow-rate in the table are for the biggest mentioned solenoid system!*

DN	Sitz Orifice Ømm	Kv-Wert Flow-rate m ³ /h	Standardtype Standard type	max. Druck bei Magnettype max. pressure regarding solenoid type				
				.322	.242	.272	.352	.402
15	15	5,0	.2401/0.01/....	0-40*	-	-	-	-
20	20	11,0	.2402/0.01/....	0-25	0-40*	-	-	-
25	25	13,0	.2403/0.01/....	0-25	0-40*	-	-	-
32	32	28,0	.2404/0.01/....	0-10	0-25	0-40*	-	-
40	40	30,0	.2405/0.01/....	0-10	0-25	0-40*	-	-
50	50	46,0	.2406/0.01/....	-	0-25	0-40*	-	-
65	65	75,0	.2407/0.01/....	-	0-16	0-40*	-	-
80	80	97,0	.2408/0.01/....	-	0-16	0-25	0-40*	-
100	100	143,0	.2409/0.01/....	-	-	0-16	0-40*	-
125	125	240,0	.2410/0.01/....	-	-	0-16	0-40*	-
150	150	370,0	.2411/0.01/....	-	-	-	0-16	0-40*
200	200	625,0	.2412/0.01/....	-	-	-	-	0-40*
250	250	950,0	.2413/0.01/....	-	-	-	-	0-16*
300	300	1400,0	.2414/0.01/....	-	-	-	-	0-10*

Maßzeichnung Standardausführung
Dimensional drawing of standard type

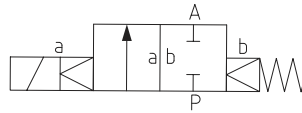
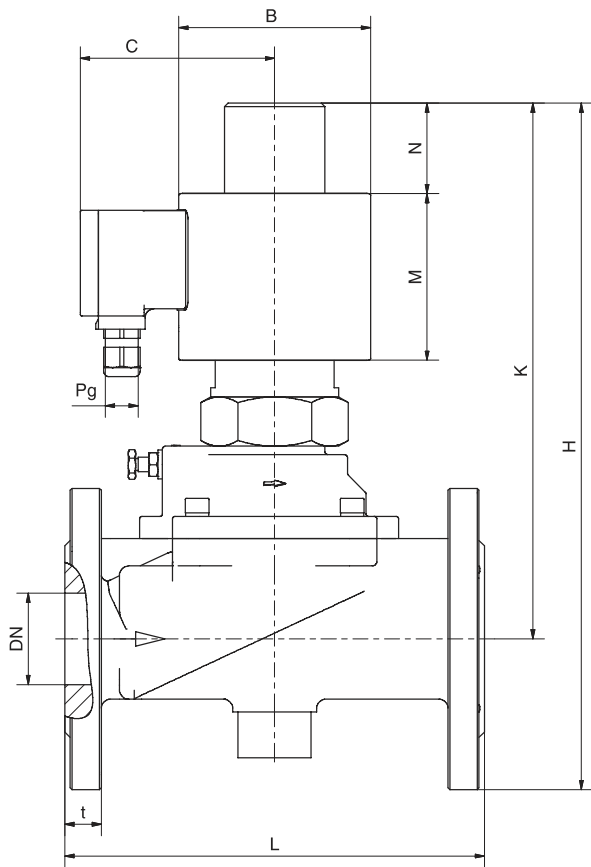

Schaltfunktion/Function:
in Ruhestellung gesperrt -
NC. Normally closed - NC.

Anschlussplan / Connection diagram

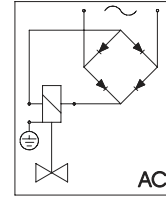
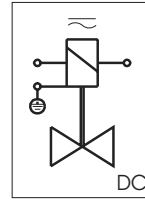

Für Gleichspannung.
For DC.

Mit vorgeschaltetem Gleichrichter
für Wechselspannung.
With rectifier for AC connection.

Erdung oder Schutzschaltung nach Vorschrift des zuständigen EVU.
Grounding or earthing of the protective circuit in accordance with
regulations of the responsible electric supply company.

Absicherung entsprechend der Stromaufnahme vorsehen.
Appropriate protection according to the power-consumption.

Magnet Solen.	.322					.242						.272						
Type	2401	2402	2403	2404	2405	2402	2403	2404	2405	2406	2407	2408	2404	2405	2406	2407	2408	
DN	15	20	25	32	40	20	25	32	40	50	65	80	32	40	50	65	80	
B	∅63	∅63	∅63	∅63	∅63	∅77	∅77	∅77	∅77	∅77	∅77	∅77	∅105	∅105	∅105	∅105	∅105	
C	76	76	76	76	76	82	82	82	82	82	82	82	95	95	95	95	95	
H	211,5	233,5	238,5	264	269	257,5	262,5	288	293	306,5	362,5	415	313	318	318	334,5	402,5	445
K	164	181	181	194	194	205	205	218	218	224	270	315	243	243	252	310	345	345
L	130	150	160	180	200	150	160	180	200	230	290	310	180	200	230	290	310	310
M	59	59	59	59	59	70	70	70	70	70	70	70	90	90	90	90	90	90
N	16	16	16	16	16	20	20	20	20	20	20	20	25	25	25	25	25	25
t	14	16	16	16	16	16	16	16	16	18	18	20	16	16	16	18	18	20
Pg	11	11	11	11	11	11	11	11	11	11	11	11	11	11	11	11	11	11
kg	5,0	5,5	6,0	8,5	10,5	7,5	8,5	11,0	13,0	14,0	35,0	44,0	13,0	16,0	21,0	38,0	47,0	47,0

Magnet Solen.	.272			.352				.402			
Type	2409	2410	2408	2409	2410	2411	2412	2411	2412	2413	2414
DN	100	125	80	100	125	150	200	150	200	250	300
B	∅105	∅105	∅145	∅145	∅145	∅145	∅145	-	-	-	-
C	95	95	120	120	120	120	120	-	-	-	-
H	510	480	580	670	545	590	630	743,5	830	922,5	980
K	400	355	480	560	420	450	460	600	660	720	750
L	350	400	310	350	400	480	600	480	600	730	850
M	90	90	145	145	145	145	145	293	293	293	293
N	25	25	20	20	20	20	20	20	20	20	20
t	22	24	20	22	24	26	28	26	26	34	38
Pg	11	11	11	11	11	11	11	11	11	11	11
kg	63,0	80,0	39,0	72,0	87,0	95,0	108,0	140	158	235,0	320,0

Alle Angaben sind freibleibend
und unverbindlich /
All technical specifications are
without obligation!

Weitere Ventilausführungen
Stromlos geöffnet / Non energised open= NO
Dichtung / Sealing= FKM,EPDM,PTFE
Andere Durchflussmedien und Viskositäten
Varying medium and viscosity ranges
Abweichende Temperaturen und Drücke
Varying temperature and pressure ranges
Stellungsanzeiger (Endschalter, ab DN20)= EH
Position indicator (reed contact, from DN20)=EH
Ex-Schutz / Explosion proof= Ex II 2G Ex e mb II T4
Grundmengeneinstellung= GM
Base of volume adjustable = GM

/

Valve options
Handbetätigung / Manual operation= HA
Regulierbare Schließdämpfung= SR(DN32-DN100 seriemäßig)
Variable close muting= SR (DN32-DN100 standard)
Für Sauerstoffanwendungen = OF
For oxygen applications= OF
Buntmetallfrei= BF
Free of non-ferrous metal=BF
Temperaturausführung bis +180°C= TH
Design for high temperature up to +180°C=TH

Stückliste - Parts list

- K1.1 Armatur / Valve body
- K2.1 Deckel / Bonnet
- *K3.1 Vorsteuersitz / Pilot seat
- *K3.2 Ventilkolben komplett / Valve piston complete
- *K3.4 Vorsteuerspindel / Pilot spindle
- *K3.7 Überwurfmutter / Union nut
- K3.10 Führungring / Guide ring
- K3.13 Dämpfungsschraube / Damping screw
- K3.14 Scheibe / Disk
- K3.15 Scheibe / Disk
- *K3.16 Nutring / U-cup seal
- *K3.17 Führungsband / Piston ring
- *K3.18 O-Ring / O-ring
- *K3.19 O-Ring / O-ring
- *K3.20 O-Ring / O-ring
- *K3.21 O-Ring / O-ring
- *K3.23 O-Ring / O-ring
- *K3.24 Scheibe / Disk
- K3.27 6-kt. Mutter / Hexagon nut
- K3.28 6-kt. Mutter / Hexagon nut
- K3.31 Gewindesttift / Grub screw
- *K3.33 Feder / Spring
- K5.1 Magnethülse / Solenoid tube
- K5.2 Magnetanker / Solenoid plunger
- K5.4 Druckstück / Pressure piece
- K5.5 O-Ring / O-ring
- K5.6 Scheibe / Disk
- K5.8 Zylinderschraube / Cylinder screw
- K5.9 Scheibe / Disk
- K6.1 Magnetspule / Solenoid

* = Bestandteil des Ersatzteilpäckchens
(je nach Ausführung freibleibend)
* = Part of the service-set. (These specifications are without obligation).

Baureihe / Type 2401-2403

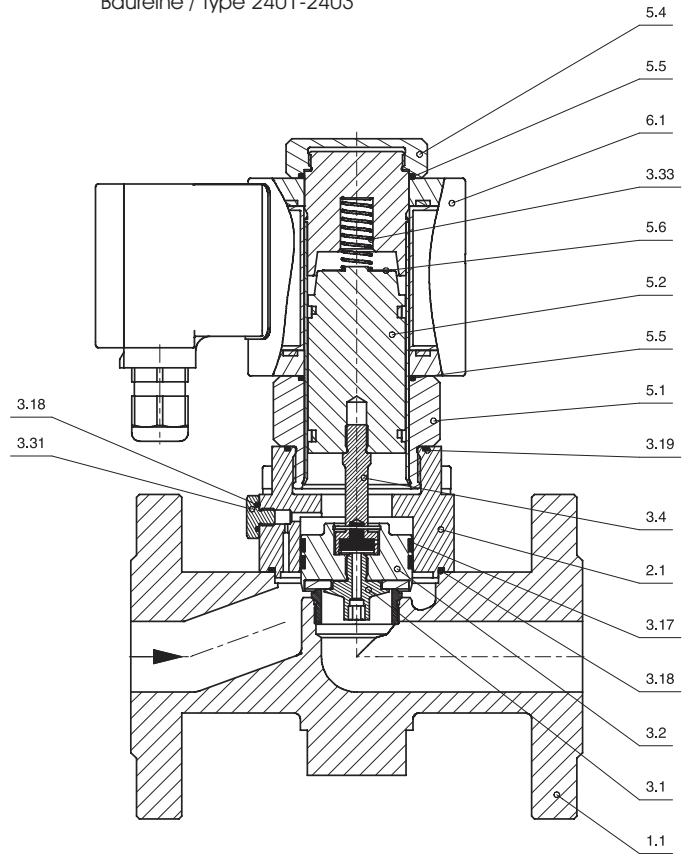

Baureihe / Type 2404 - 2409

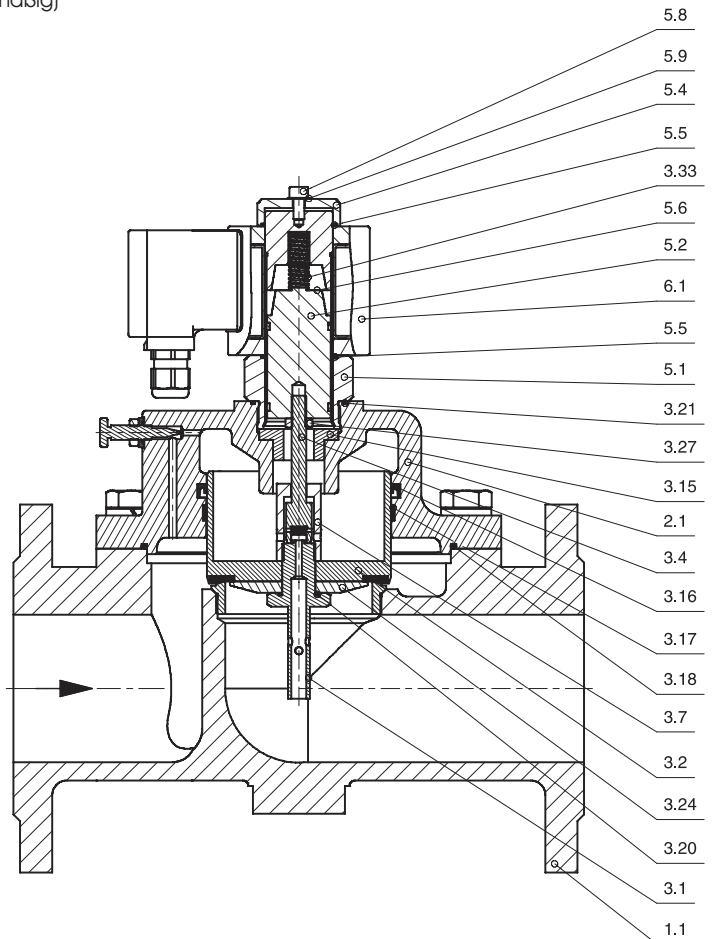

Regulierbare Schließdämpfung - SR (von DN32-DN100 serienmäßig)
Adjustable close muting - SR (from DN32-DN100 standard)

Schraube nach rechts drehen : Ventil schließt langsamer
Screw to the right site : Valve closes- slower
Schraube nach links drehen : Ventil schließt schneller
Screw to the left site : Valve closes - faster

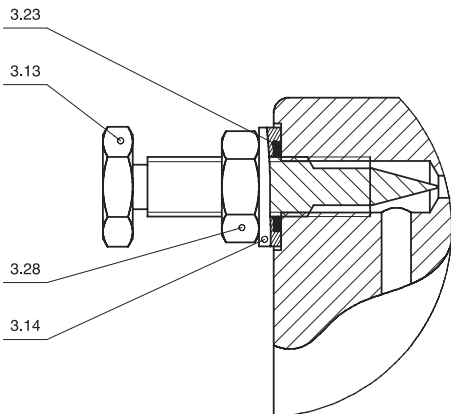

Handbetätigung - HA
Manual operation - HA

- K3.62 Spindel / Spindle
- K3.63 Verschraubung / Screw joint
- K3.64 Scheibe / Disk
- K3.65 Nutring / U-cup ring
- K3.67 Handrad / Handwheel
- K3.68 Zylinderschraube / Cyl.-screw

Ventiloptionen / Optional extras

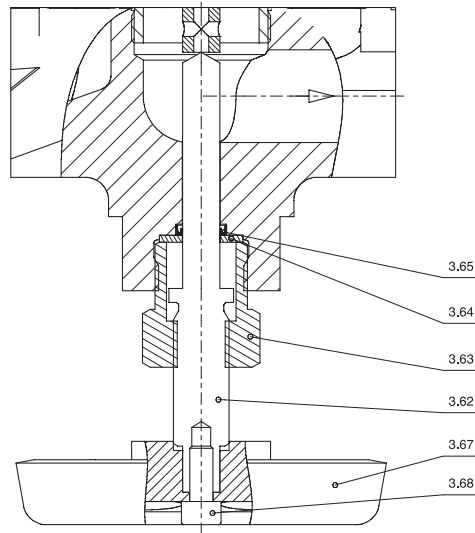

Stellungsanzeiger - EH (ab DN20)
Position indicator - EH (from DN20)

- K3.75 Zwischenverschraubung / Screw joint
- K3.76 Spindel / Spindle
- K3.77 O-Ring / O-ring
- K3.79 Befestigungsmutter / Union nut
- K3.82 Senkschraube / Screw
- K3.83 Permanentmagnet / Permanent magnet
- K3.84 Klemmring / Clamp ring
- K3.85 Verschraubung / Screw joint
- K3.86 Endschalter / Position indicator
- K3.87 Scheibe / Disk

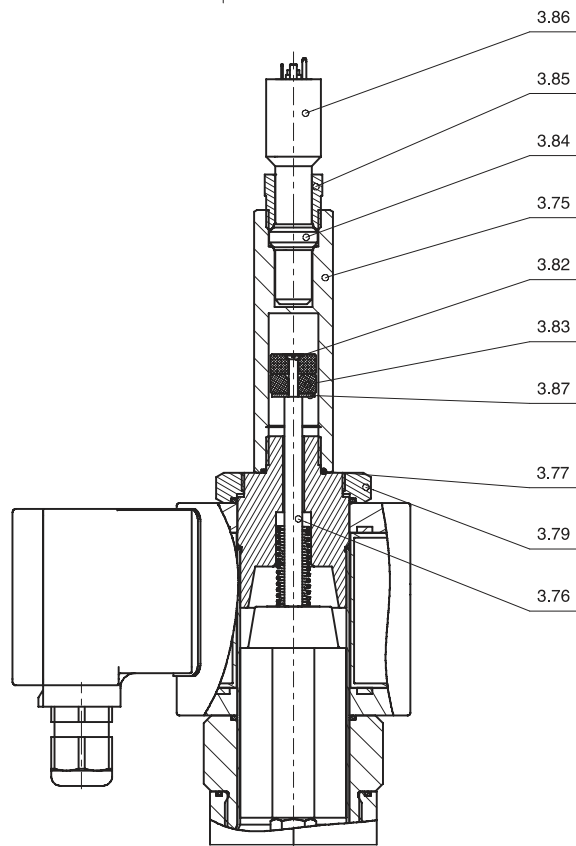

Anschlussplan
Connection plan

Endschalter / Position indicator

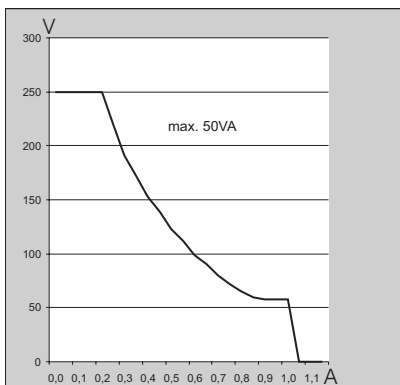
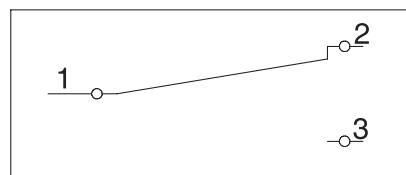

Schaltleistungsdiagramm
Braking capacity-graph